

DESIGN NOTES

LTC1560-1: Tiny 1MHz Lowpass Filter Uses No Inductors

Design Note 169

Nello Sevastopoulos

The LTC[®]1560-1 is a fully integrated continuous-time filter in an SO-8 package. It provides a 5-pole elliptic response with a pin selectable cutoff frequency (f_c) of 1MHz or 500kHz. Several features distinguish the LTC1560-1 from other commercially available high frequency, continuous-time monolithic filters:

- 5-pole 0.5MHz/1MHz elliptic in an SO-8 package
- 70dB signal-to-noise ratio (SNR) measured at 0.07% THD
- 75dB signal-to-noise ratio (SNR) measured at 0.5% THD
- 60dB or more stopband attenuation
- No external components required other than supply and ground decoupling capacitors

The LTC1560-1 delivers accurate fixed cutoff frequencies of 500kHz and 1MHz without the need for internal or external clocks. Other cutoff frequencies can be obtained upon demand; please consult LTC marketing. The extremely small size of the part makes it suitable for compact designs that were never before possible using discrete RC active or RLC passive filter designs.

Frequency and Time-Domain Response

Figure 1 shows a simple circuit for evaluating the performance of the filter. The LTC1560-1 offers a pin-selectable cutoff frequency of either 500kHz or 1MHz. The filter gain response is shown in Figure 2. In the 1MHz mode, the

passband gain is flat up to $(0.55)(f_c)$ with a typical ripple of ± 0.2 dB, increasing to ± 0.3 dB for input frequencies up to $(0.9)(f_c)$. The stopband attenuation is 63dB starting from $(2.43)(f_c)$ and remains at least 60dB for input frequencies up to 10MHz.

The elliptic transfer function of the LTC1560-1 was chosen as a compromise between selectivity and transient response. Figure 3a shows the 2-level eye diagram of the filter. The size of the “eye” opening shows that the filter is suitable for data communications applications. Additional phase equalization can be performed with the help of an external dual op amp and a few passive components. This is shown in Figure 4, where a 2nd order allpass equalizer is cascaded with the IC. The allpass function is achieved through traditional techniques, namely, passing a signal through a low Q inverting bandpass filter and then performing summation with the appropriate gain factors. Figure 3b shows the eye diagram of the equalized filter.

DC Accuracy

For applications where very low DC offset and DC accuracy are required, the DC offset of the filter can be easily corrected, as shown in Figure 5.

The input amplifier stores the DC offset of the IC across its feedback capacitor. The total output DC offset is the input DC offset of the 1/2 LT1364 plus its offset current times the

LT, LTC and LT are registered trademarks of Linear Technology Corporation.

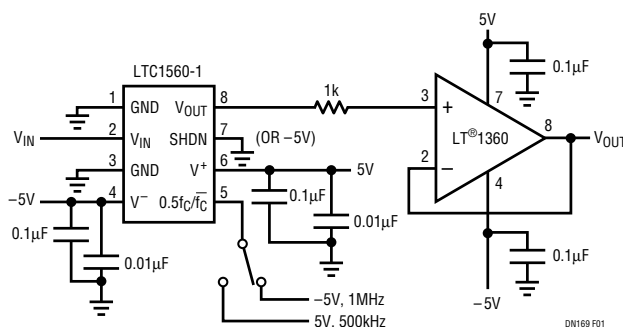

Figure 1. A Typical Circuit for Evaluating the Full Performance of the LT1560-1

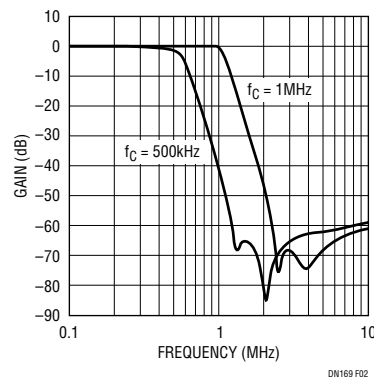

Figure 2. Gain vs Frequency of the 1MHz and 500kHz

10k resistor (less than 1.85mV). Upon power-up, the initial settling time of the circuit is dominated by the RC time constant of the DC correcting feedback path; once the DC offset of the LTC1560-1 is stored, the transient behavior of the circuit is dictated by the elliptic filter.

Conclusion

The LTC1560-1 is a 5th order, user friendly, elliptic lowpass filter suitable for any compact design. It is a monolithic replacement for larger, more expensive and less accurate solutions in communications and data acquisition.

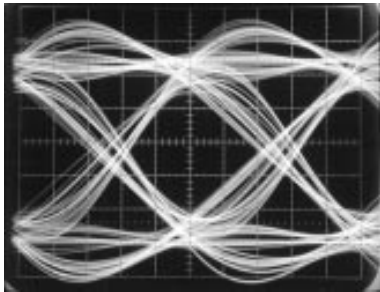

Figure 3a. 2-Level Eye Diagram of the LTC1560-1 Before Equalization

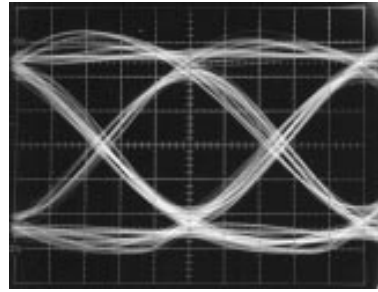

Figure 3b. 2-Level Eye Diagram of the Equalized Filter

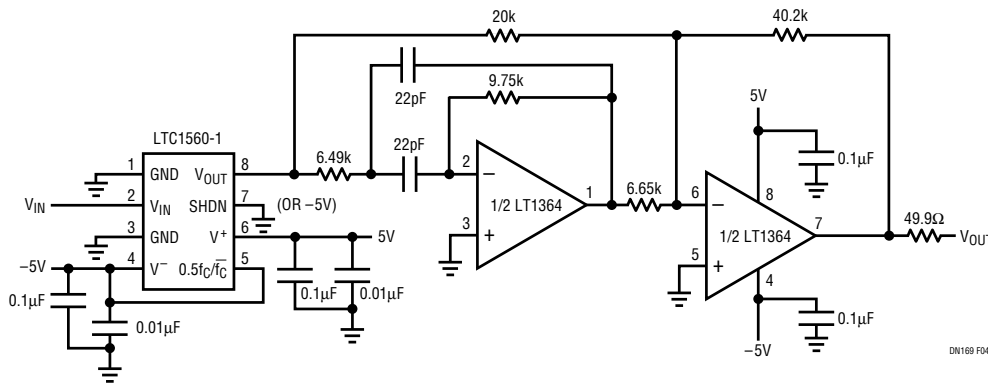

Figure 4. Augmenting the LTC1560-1 for Improved Delay Flatness

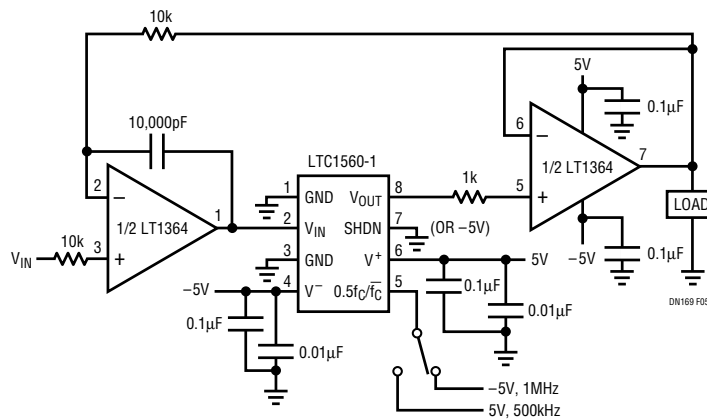

Figure 5. A DC Accurate 500kHz/1MHz Elliptic Filter with an Output Buffer for Driving Cables or Capacitive Loads

For literature on our Monolithic Filters, call **1-800-4-LINEAR**. For applications help, call (408) 432-1900, Ext. 2453